

# Instrumented Micropiles

Robert Taylor, P.Eng.

International Workshop on Micropiles

Schrobenhausen, May 2006

# Micropiles

- Titan Bars
- Threaded
- Hollow
- Drill and install in one operation
- Through-grouted
- Sizes 30/16 to 73/53 OD/ID
- UTS 220-8000 kN

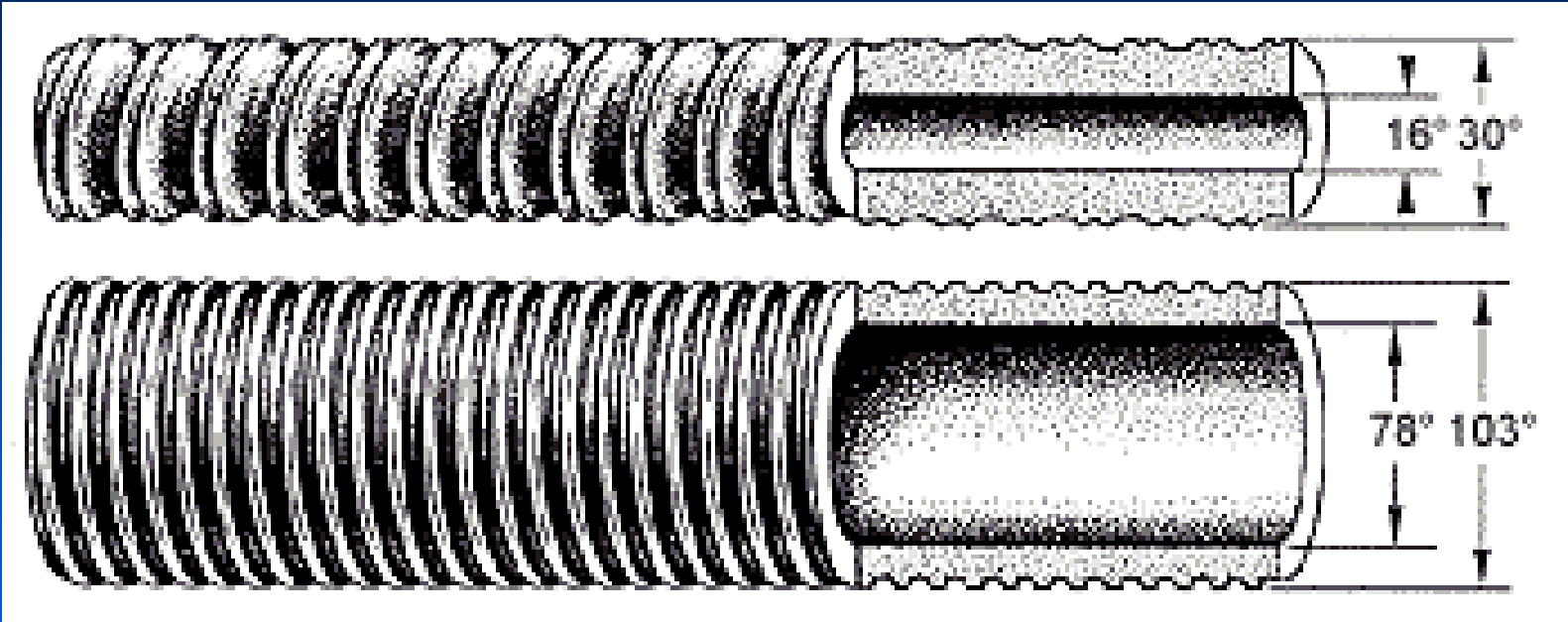

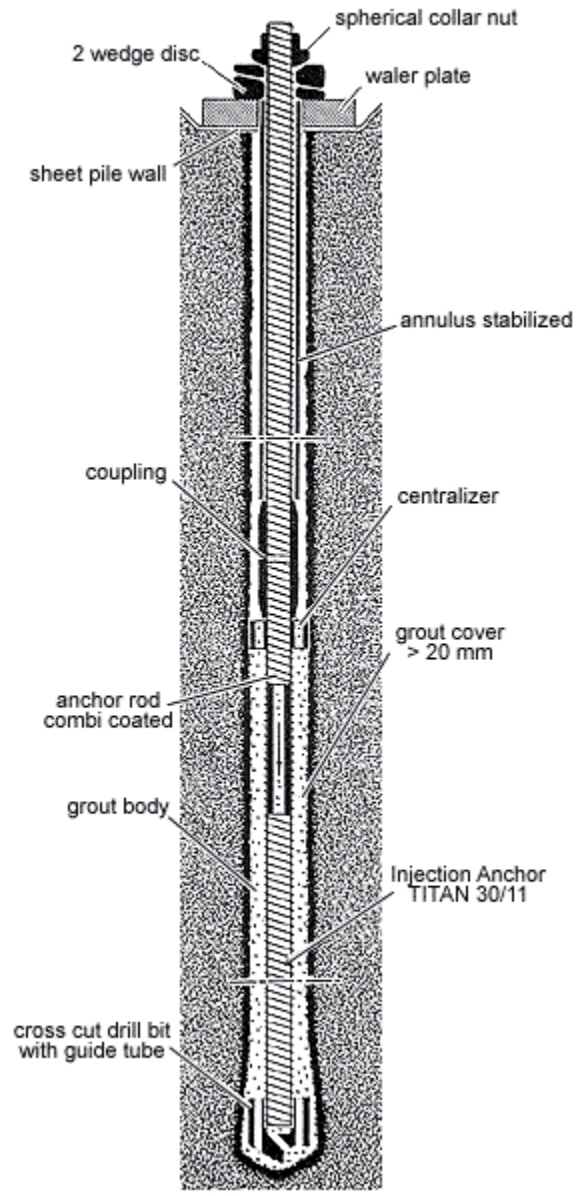

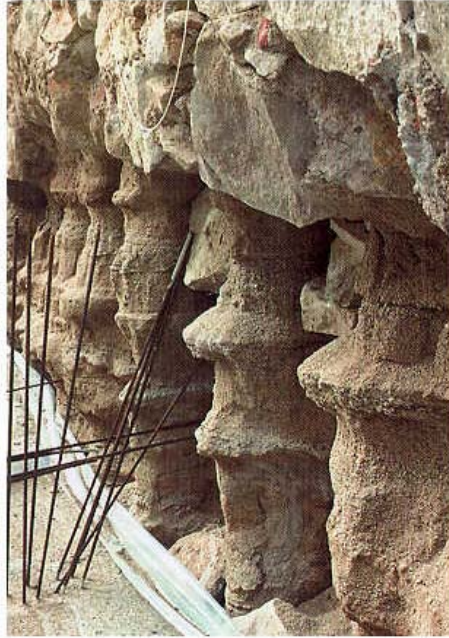

# Micropile Strain Gauge

- 150mm VW strain gauges
- Installed after drilling – no damage
- Uses grout that's already there
- Multiple installations possible
- Protected inside micropile
- Reliable multi-zone load monitoring

# Sensor Design

- Vibrating wire embedment gauge
- Excellent immunity to cable moisture
- Cable readily shortened/extended without effect on results
- 150 mm length gives averaging of grout discontinuities
- Compliant carrier centers the gauge on the neutral axis, facilitates passage through couplings

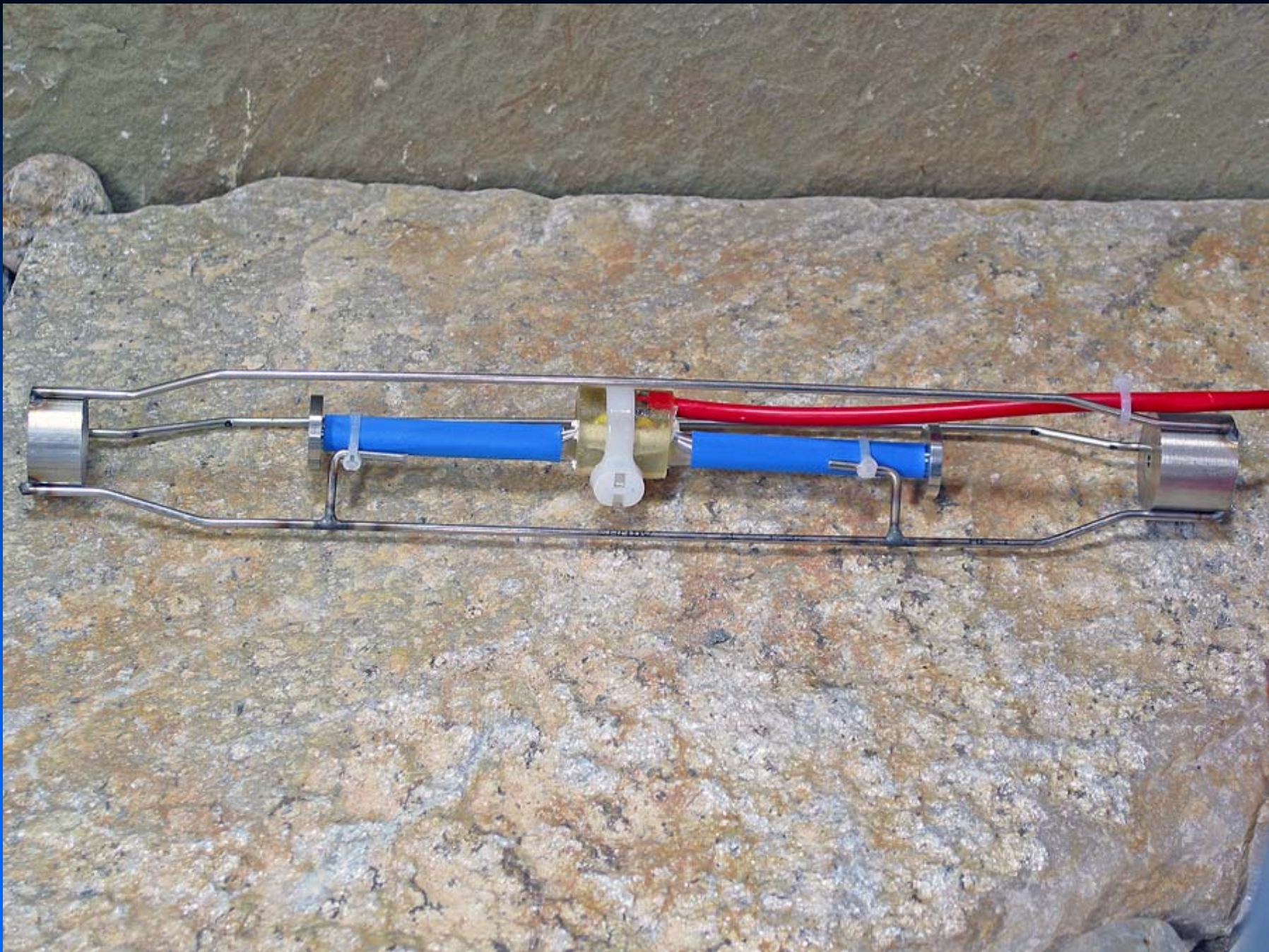



# Installation Method

- Drill and fully grout pile
- Finish with high-strength cement grout
  - e.g. W/C 0.45
- While grout still fluid, push in VW strain gauge using low-modulus rods
- Readings as soon as grout sets
- Readings during load application

# Test Program

- To facilitate interpretation of data from micropile strain data, controlled load of instrumented bar made
- Because micropiles can be applied in tensile and compressive directions, both load directions tested
- Tensile test made with hollow jack
- Compressive test made on shortened bar

# Specimen Preparation

- On production site, test 73 x 53 OD x ID pile drilled 40 cm into soil, grouted, and gauge inserted
- Following day grout found to have escaped, exposing gauge
- Bar regouted, tapped to release bubbles
- Grout cured 25 days in soils laboratory

# Tensile Test

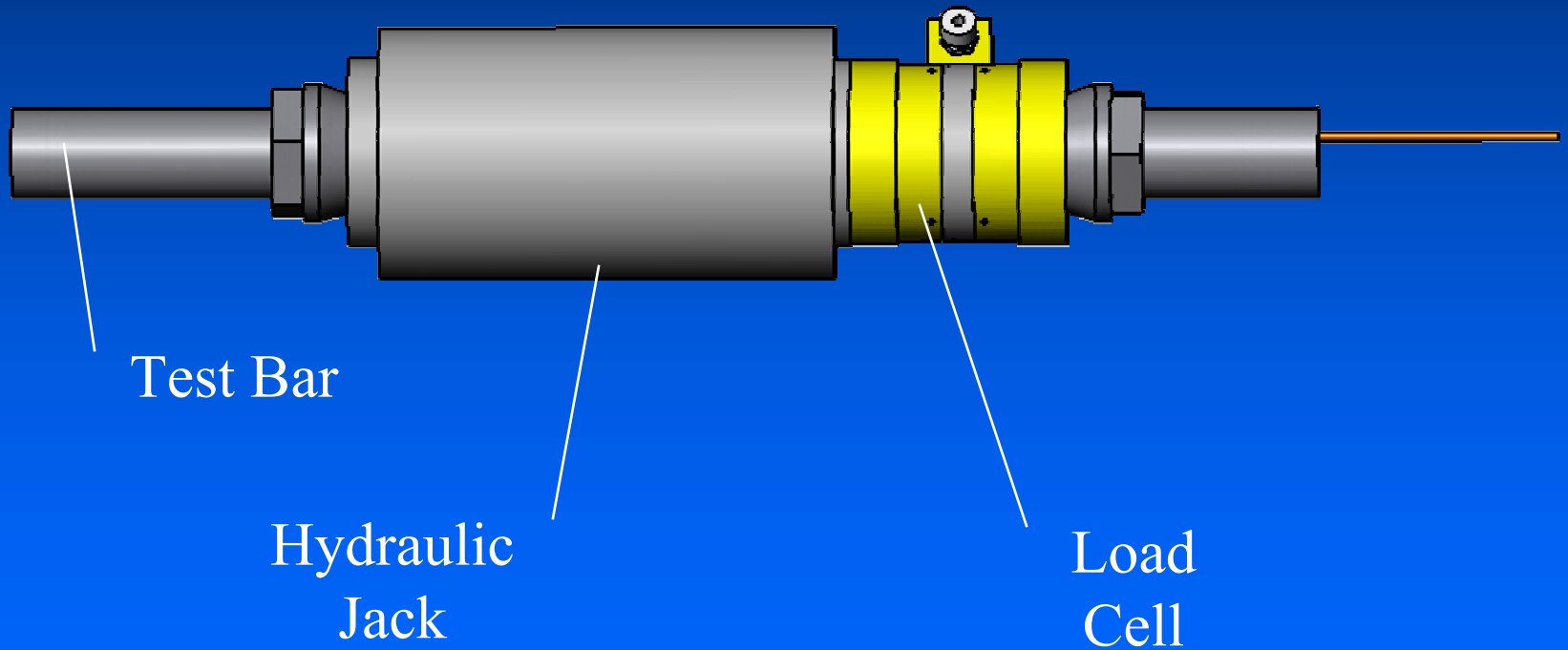

# Compressive Test

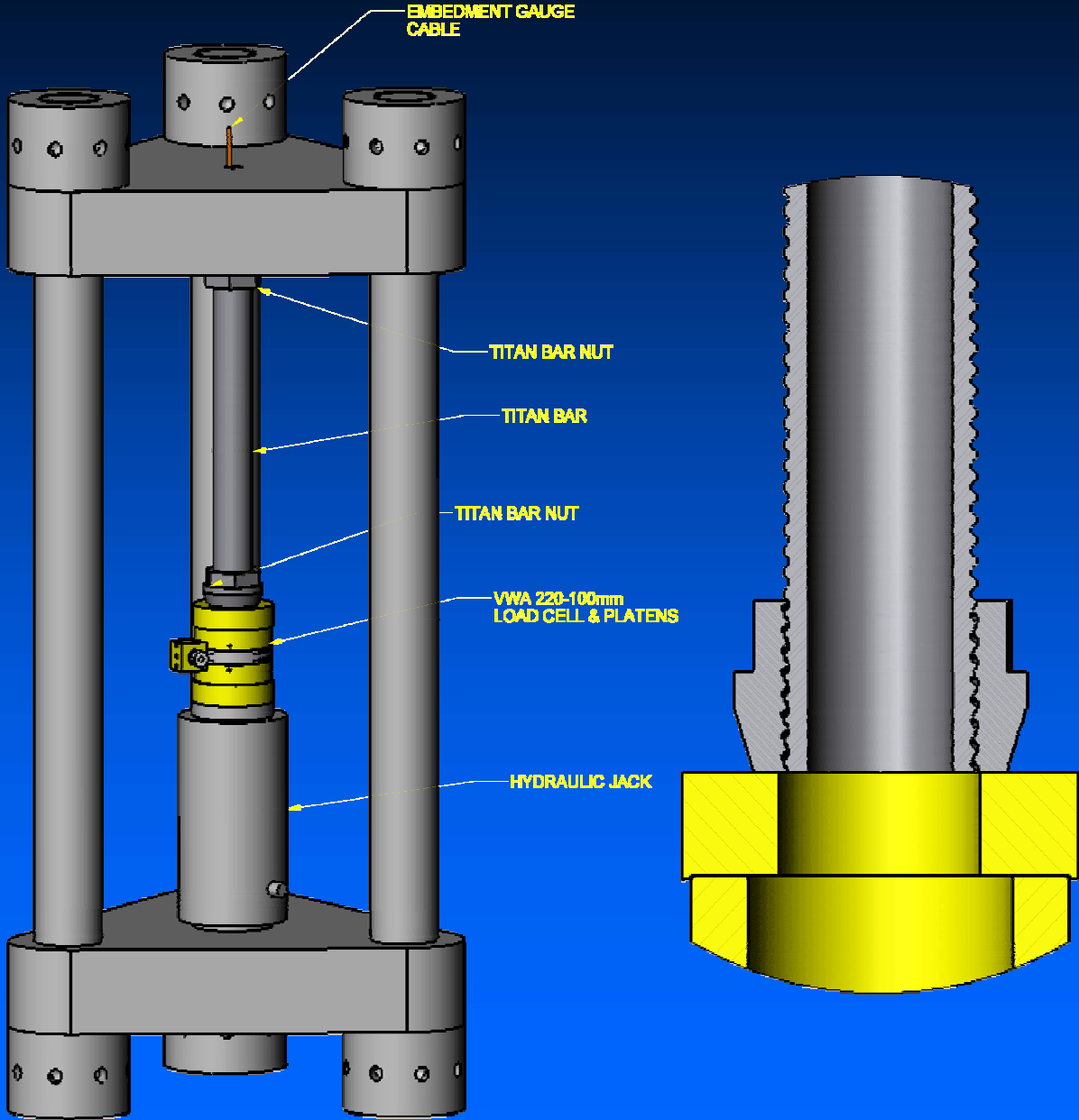

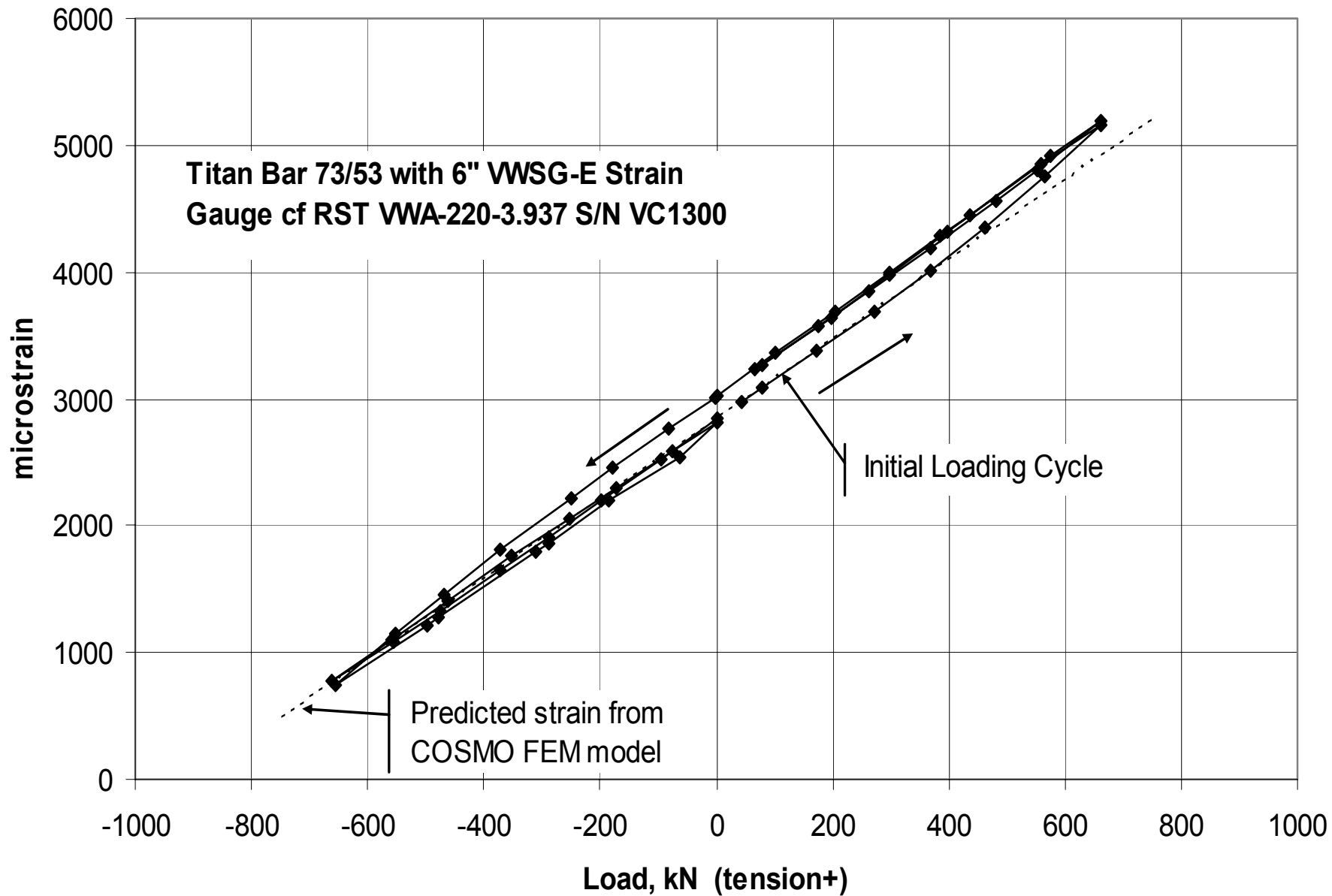

# Results

- Proportional response
- Minor non-linearity on first loading to upper values
- Recovery and reloading response linear, repeatable; matches prediction of finite element model

# Inspection

- After testing, the specimen bar was sectioned longitudinally
- The sectioning cuts were made by end milling, flooded in coolant to a residual thickness of 1.25 mm
- Coolant was excluded using plastic mastic
- The last 1.25 mm was cut using high-speed dry abrasive wheel



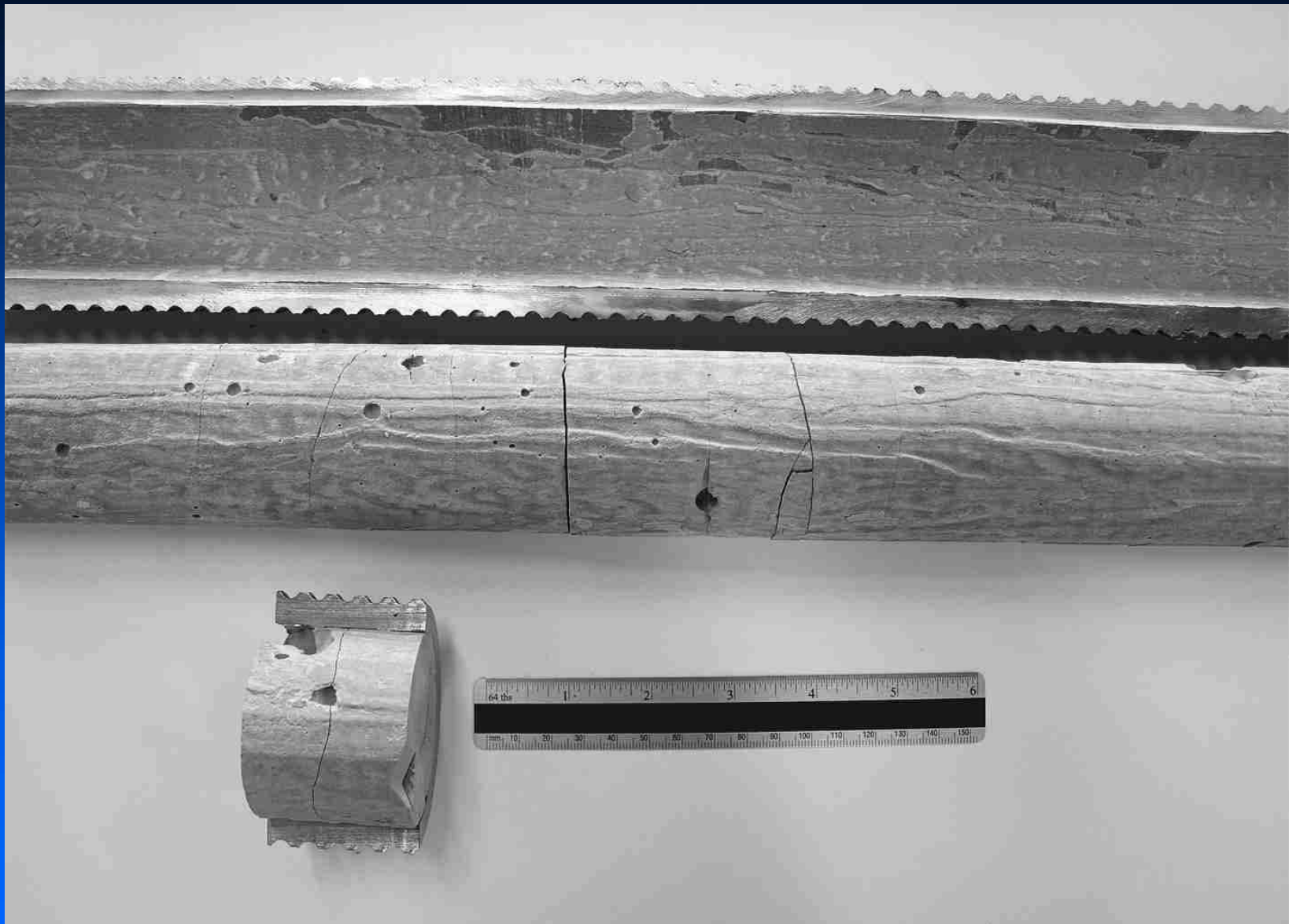

# Inspection continued

- When first side metal was cut through, the micropile sprung open, with the grout remaining tightly retained on one side
- The grout had to be pried out, resulting in transverse fracturing in what appeared to be intact material
- Artifacts of specimen preparation problems (bubbles, parting at regrouting surface) had no apparent effect on performance

# Recommendations

- It is desirable to install into a fully grouted pile, and to avoid subsequent loss of grout – a positive grout retention system should be used
- Caution should be used in inferring load from strains on initial loading
- For large peak-peak strains ( $>2000 \mu\epsilon$ ), biasing installation strains and/or desensitized gauges required

# Conclusions

- After initial loading, subsequent unloading and reloading are typically very linear
- The method appears a robust, practical way to measure load in injection bored micropiles